

D100/200-Series

D261

- Door Type:** Wood or Composite, Flat or Beveled
- Door Thickness:** 1 3/8" (35mm) – 1 7/8" (48mm)
- Faceplate:** Round Corner, 1/4" (6mm) Radius, 1" (25mm) wide
- Backsets:** FD116-C, 2 3/8" (60mm) | FD116-D, 2 3/4" (70mm)

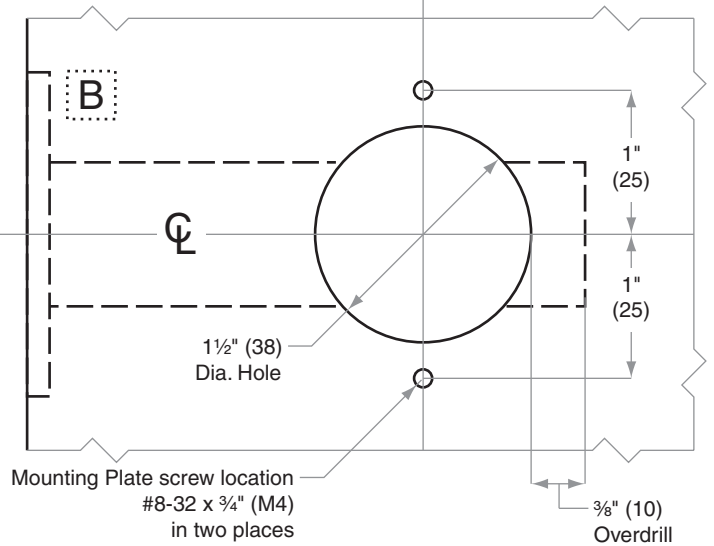
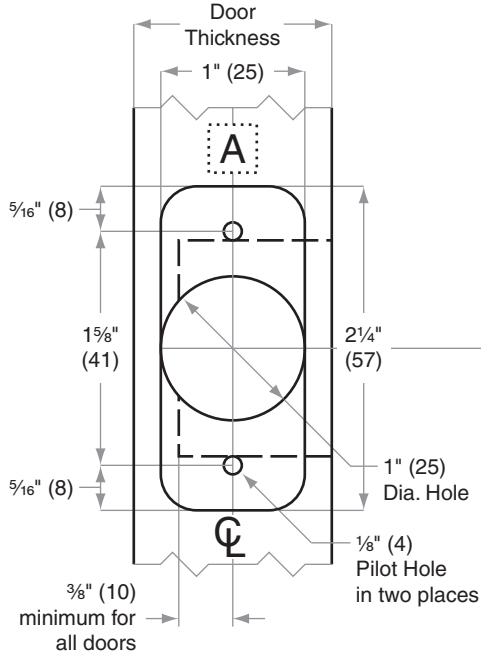
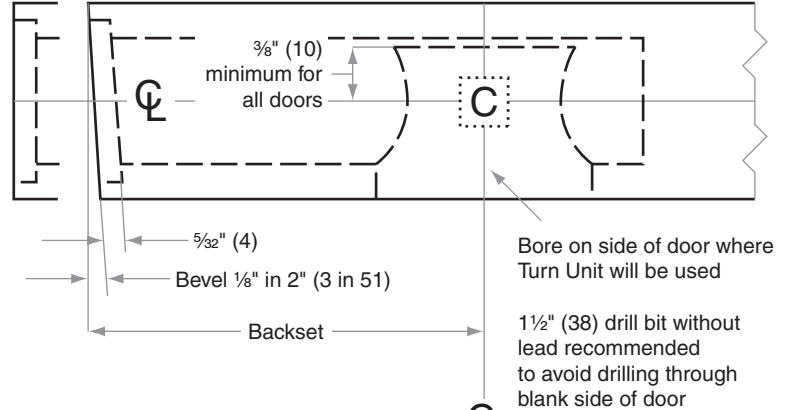
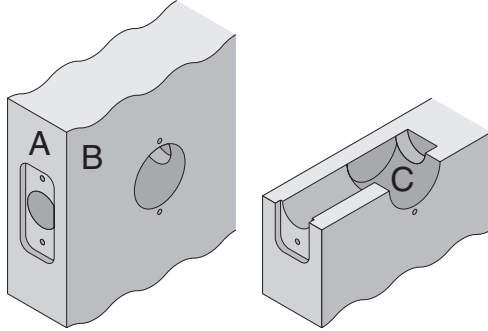

Dimensions shown in parentheses () are in millimeters

Job: _____

Date: _____

Door Thickness: _____

Remarks: _____

TEMPLATE
FD116